

Gutor PXC

25-100 kVA

Operation

03/2018



Legal Information

The Schneider Electric brand and any registered trademarks of Schneider Electric Industries SAS referred to in this guide are the sole property of Schneider Electric SA and its subsidiaries. They may not be used for any purpose without the owner's permission, given in writing. This guide and its content are protected, within the meaning of the French intellectual property code (Code de la propriété intellectuelle français, referred to hereafter as "the Code"), under the laws of copyright covering texts, drawings and models, as well as by trademark law. You agree not to reproduce, other than for your own personal, noncommercial use as defined in the Code, all or part of this guide on any medium whatsoever without Schneider Electric's permission, given in writing. You also agree not to establish any hypertext links to this guide or its content. Schneider Electric does not grant any right or license for the personal and noncommercial use of the guide or its content, except for a non-exclusive license to consult it on an "as is" basis, at your own risk. All other rights are reserved.

Electrical equipment should be installed, operated, serviced, and maintained only by qualified personnel. No responsibility is assumed by Schneider Electric for any consequences arising out of the use of this material.

As standards, specifications, and designs change from time to time, please ask for confirmation of the information given in this publication.

Table of Contents

Important Safety Instructions — SAVE THESE INSTRUCTIONS	5
FCC Statement	6
Safety Precautions	6
Overview	9
UPS without Transformer	9
System Overview	9
UPS with Transformer	11
System Overview	11
User Interface	15
Display	18
View System Status	20
View System Configuration	21
Operation	23
Operation Modes	23
Operation Procedures	25
Turn on the UPS	25
Turn off the UPS	25
Transfer from Normal Operation to ECO Mode	25
Transfer from ECO Mode to Normal Operation	25
Transfer from Normal Operation to Requested Static Bypass Operation	25
Transfer from Requested Static Bypass Operation to Normal Operation	26
Transfer from Normal Operation to Maintenance Bypass Operation	26
Transfer from Maintenance Bypass Operation to Normal Operation	27
Transfer from Normal Operation or ECO Mode to Maintenance Bypass Operation – Redundant Parallel UPS System N+1	29
Transfer from Maintenance Bypass Operation to Normal Operation or ECO Mode – Redundant Parallel UPS System N+1	30
View the Event Log	31
Clear the Event Log	31
View the Alarms	31
View Diagnosis	32
View Statistics	33
Clear Statistics	33
Configuration	34
Set the Date and Time	34
Set Up the Display	34
Reset the Display Language to English	35
Set Auto Start, Auto Boost, LCM Alerts, and ECO Mode	35
Set Battery Charge Mode	36
Maintenance	37
Replace the Filters	37
Perform LED and Display Test	37

Perform Advanced Battery Monitoring (ABM) Test.....	37
Perform Discharge Test.....	38
Life Cycle Monitoring (LCM)	39
Troubleshooting	40
Log Events.....	42
Alarm LEDs.....	47
Input Contacts and Output Relays.....	48

Important Safety Instructions — SAVE THESE INSTRUCTIONS

Read these instructions carefully and look at the equipment to become familiar with it before trying to install, operate, service or maintain it. The following safety messages may appear throughout this manual or on the equipment to warn of potential hazards or to call attention to information that clarifies or simplifies a procedure.



The addition of this symbol to a “Danger” or “Warning” safety message indicates that an electrical hazard exists which will result in personal injury if the instructions are not followed.



This is the safety alert symbol. It is used to alert you to potential personal injury hazards. Obey all safety messages with this symbol to avoid possible injury or death.

DANGER

DANGER indicates a hazardous situation which, if not avoided, **will result in death or serious injury**.

Failure to follow these instructions will result in death or serious injury.

WARNING

WARNING indicates a hazardous situation which, if not avoided, **could result in death or serious injury**.

Failure to follow these instructions can result in death, serious injury, or equipment damage.

CAUTION

CAUTION indicates a hazardous situation which, if not avoided, **could result in minor or moderate injury**.

Failure to follow these instructions can result in injury or equipment damage.

NOTICE

NOTICE is used to address practices not related to physical injury. The safety alert symbol shall not be used with this type of safety message.

Failure to follow these instructions can result in equipment damage.

Please Note

Electrical equipment should only be installed, operated, serviced, and maintained by qualified personnel. No responsibility is assumed by Schneider Electric for any consequences arising out of the use of this material.

A qualified person is one who has skills and knowledge related to the construction, installation, and operation of electrical equipment and has received safety training to recognize and avoid the hazards involved.

FCC Statement

NOTE: This equipment has been tested and found to comply with the limits for a Class A digital device, pursuant to Part 15 of the FCC Rules. These limits are designed to provide reasonable protection against harmful interference when the equipment is operated in a commercial environment. This equipment generates, uses, and can radiate radio frequency energy and, if not installed and used in accordance with the instruction manual, may cause harmful interference to radio communications. Operation of this equipment in a residential area is likely to cause harmful interference in which case the user will be required to correct the interference at his own expense.

Any changes or modifications not expressly approved by the party responsible for compliance could void the user's authority to operate the equipment.

Safety Precautions

⚠ DANGER

HAZARD OF ELECTRIC SHOCK, EXPLOSION, OR ARC FLASH

All safety instructions in this document must be read, understood and followed.

Failure to follow these instructions will result in death or serious injury.

⚠ DANGER

HAZARD OF ELECTRIC SHOCK, EXPLOSION, OR ARC FLASH

Read all instructions in the Installation Manual before installing or working on this UPS system.

Failure to follow these instructions will result in death or serious injury.

⚠ DANGER

HAZARD OF ELECTRIC SHOCK, EXPLOSION, OR ARC FLASH

Do not install the UPS system until all construction work has been completed and the installation room has been cleaned.

Failure to follow these instructions will result in death or serious injury.

⚠ DANGER

HAZARD OF ELECTRIC SHOCK, EXPLOSION, OR ARC FLASH

- The product must be installed according to the specifications and requirements as defined by Schneider Electric. It concerns in particular the external and internal protections (upstream breakers, battery breakers, cabling, etc.) and environmental requirements. No responsibility is assumed by Schneider Electric if these requirements are not respected.
- After the UPS system has been electrically wired, do not start up the system. Start-up must only be performed by Schneider Electric.

Failure to follow these instructions will result in death or serious injury.

⚠ DANGER

HAZARD OF ELECTRIC SHOCK, EXPLOSION, OR ARC FLASH

The UPS system must be installed according to local and national regulations. Install the UPS according to:

- IEC 60364 (including 60364-4-41 - protection against electric shock, 60364-4-42 - protection against thermal effect, and 60364-4-43 - protection against overcurrent), **or**
- NEC NFPA 70, **or**
- Canadian Electrical Code (C22.1, Part 1)

depending on which one of the standards apply in your local area.

Failure to follow these instructions will result in death or serious injury.

⚠ DANGER

HAZARD OF ELECTRIC SHOCK, EXPLOSION, OR ARC FLASH

- Install the UPS system in a temperature controlled indoor environment free of conductive contaminants and humidity.
- Install the UPS system on a non-flammable, level and solid surface (e.g. concrete) that can support the weight of the system.

Failure to follow these instructions will result in death or serious injury.

⚠ DANGER

HAZARD OF ELECTRIC SHOCK, EXPLOSION, OR ARC FLASH

The UPS is not designed for and must therefore not be installed in the following unusual operating environments:

- Damaging fumes
- Explosive mixtures of dust or gases, corrosive gases, or conductive or radiant heat from other sources
- Moisture, abrasive dust, steam or in an excessively damp environment
- Fungus, insects, vermin
- Salt-laden air or contaminated cooling refrigerant
- Pollution degree higher than 2 according to IEC 60664-1
- Exposure to abnormal vibrations, shocks, and tilting
- Exposure to direct sunlight, heat sources, or strong electromagnetic fields

Failure to follow these instructions will result in death or serious injury.

⚠ DANGER

HAZARD OF ELECTRIC SHOCK, EXPLOSION, OR ARC FLASH

Do not drill or cut holes for cables or conduits with the gland plates installed and do not drill or cut holes in close proximity to the UPS.

Failure to follow these instructions will result in death or serious injury.

⚠ WARNING

HAZARD OF ARC FLASH

Do not make mechanical changes to the product (including removal of cabinet parts or drilling/cutting of holes) that are not described in the Installation Manual.

Failure to follow these instructions can result in death, serious injury, or equipment damage.

NOTICE**RISK OF OVERHEATING**

Respect the space requirements around the UPS system and do not cover the product's ventilation openings when the UPS system is in operation.

Failure to follow these instructions can result in equipment damage.

NOTICE**RISK OF EQUIPMENT DAMAGE**

Do not connect the UPS output to regenerative load systems including photovoltaic systems and speed drives.

Failure to follow these instructions can result in equipment damage.

Overview

UPS without Transformer

System Overview

One Line Diagrams

25-50 kVA

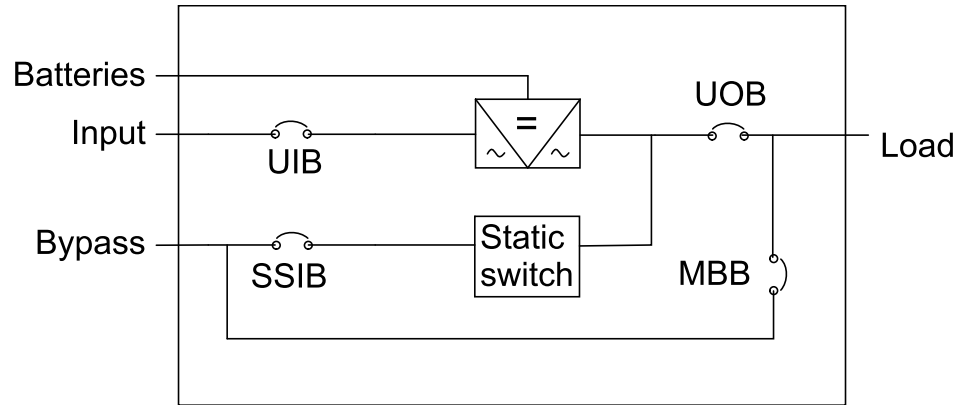

75-100 kVA

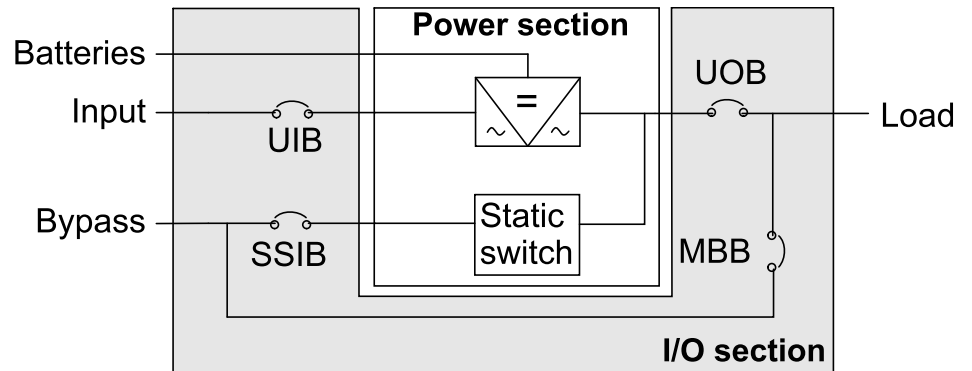

Breaker Overview

25–50 kVA (50 kVA UPS Shown)

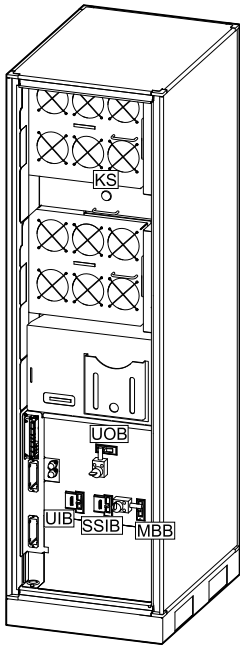

75–100 kVA (100 kVA UPS Shown)

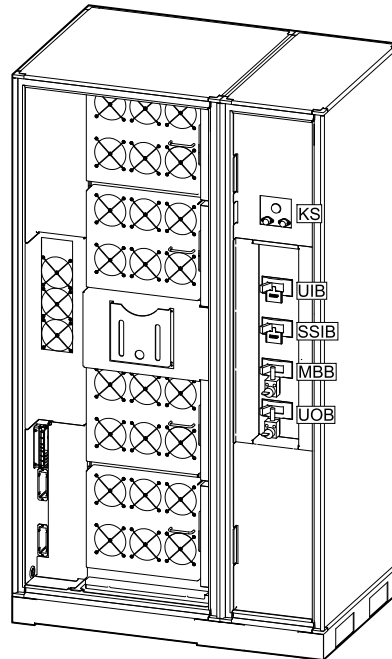

UIB	Unit input breaker
SSIB	Static switch input breaker
MBB	Maintenance bypass breaker
UOB	Unit output breaker
BB	Battery breaker in the external battery solution (not shown here)
KS	Kirk key solenoid interlock

UPS with Transformer

System Overview

One Line Diagrams

NOTE: Individual cabinets are not shown in the one line drawings.

25–50 kVA – Single Mains

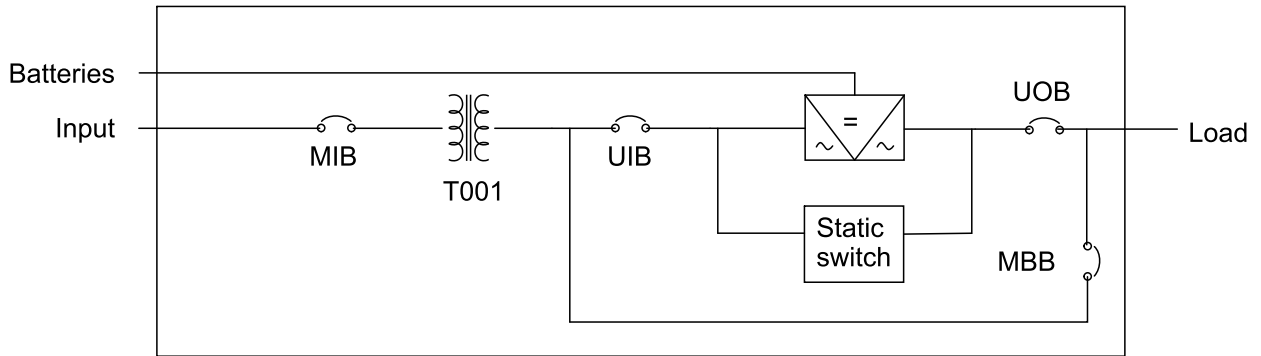

25–50 kVA – Dual Mains

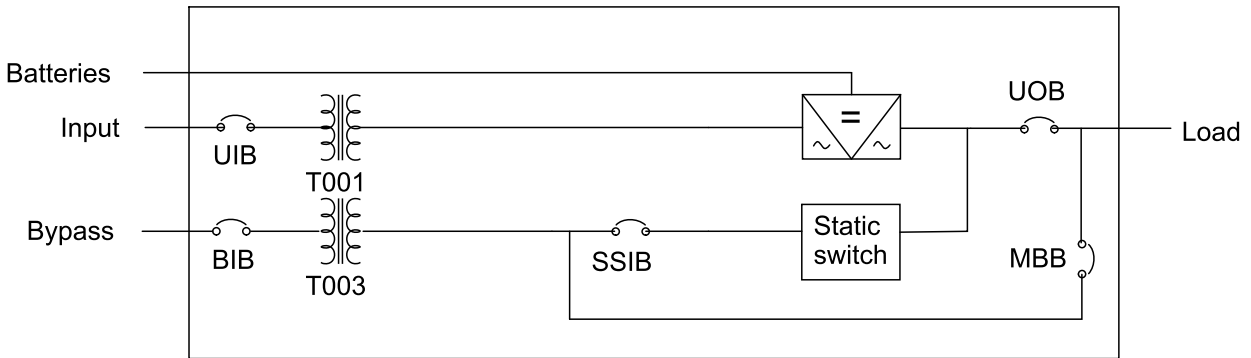

75–100 kVA – Single Mains

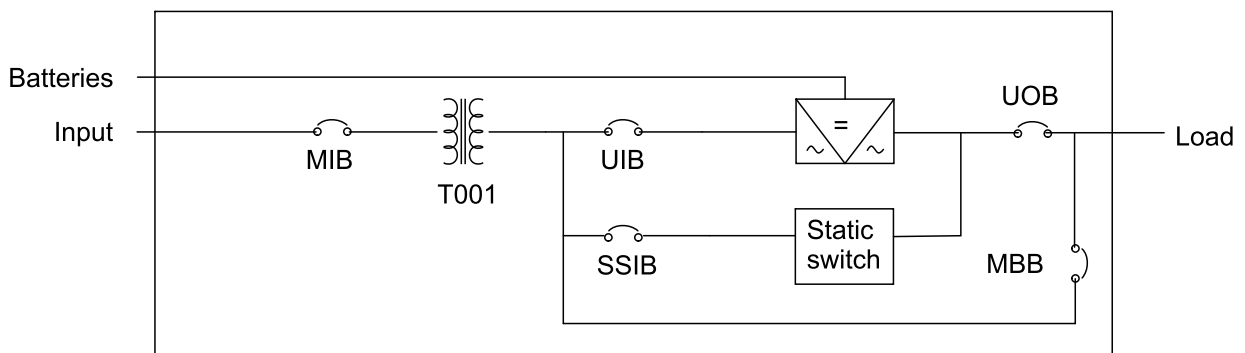

75–100 kVA – Dual Mains

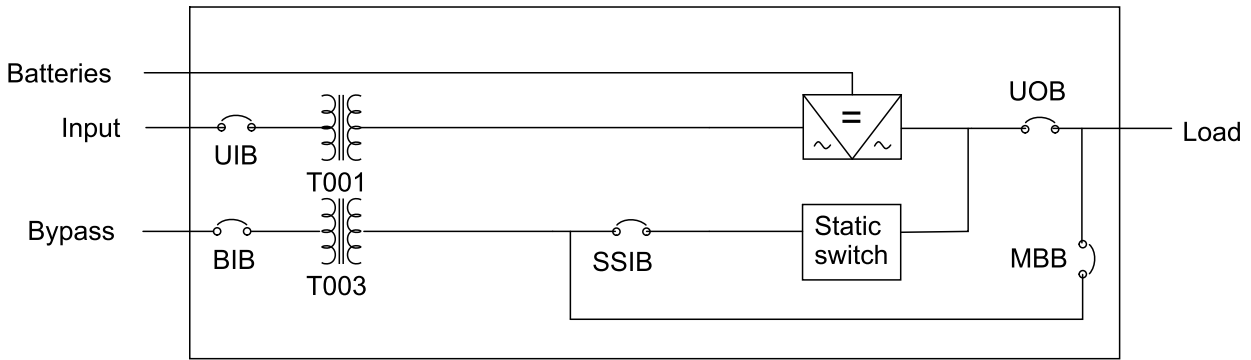

Breaker Overview

NOTE: The 25–37.5 kVA UPS for single mains does not have a transformer cabinet as the input transformer is placed inside the UPS cabinet. Breakers are the same as shown here.

MIB	Mains input breaker
BIB	Bypass input breaker
UIB	Unit input breaker
SSIB	Static switch input breaker
MBB	Maintenance bypass breaker
UOB	Unit output breaker
BB	Battery breaker in the external battery solution (not shown here)
KS	Kirk key solenoid interlock

25–50 kVA – Bottom Entry System for Single Mains (50 kVA UPS Shown)

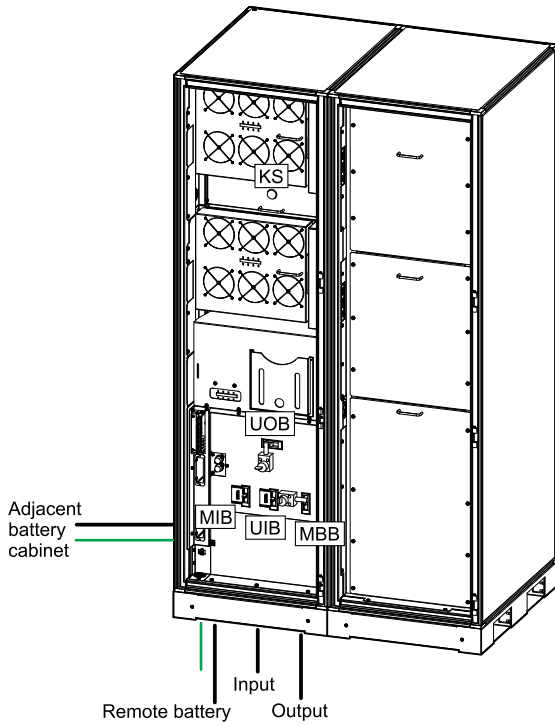

25–50 kVA – Bottom Entry System for Dual Mains (50 kVA UPS Shown)

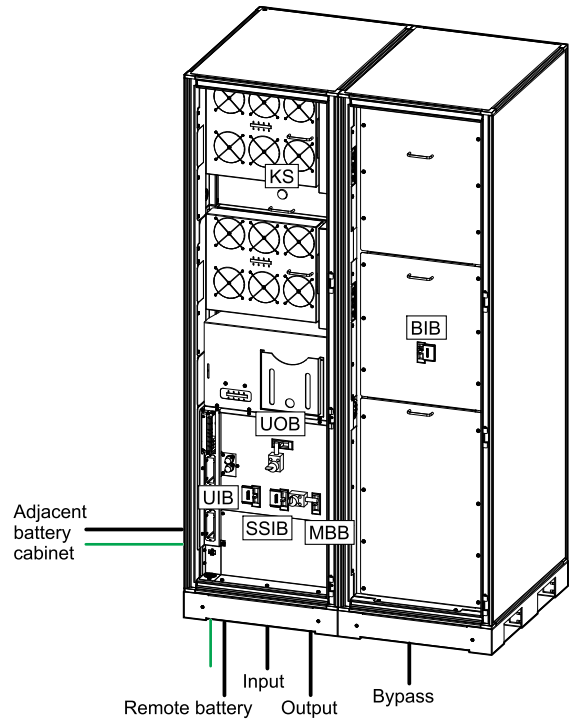

25–50 kVA – Top Entry System for Single Mains (50 kVA UPS Shown)

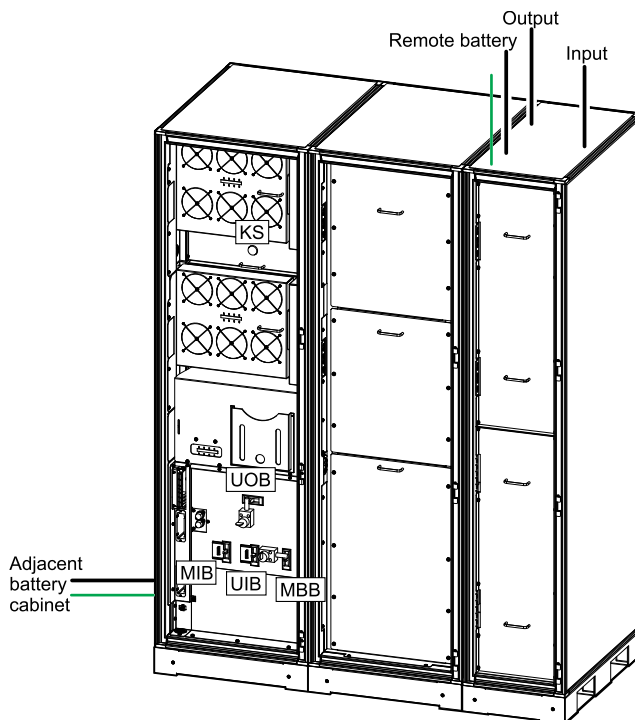

25–50 kVA – Top Entry System for Dual Mains (50 kVA UPS Shown)

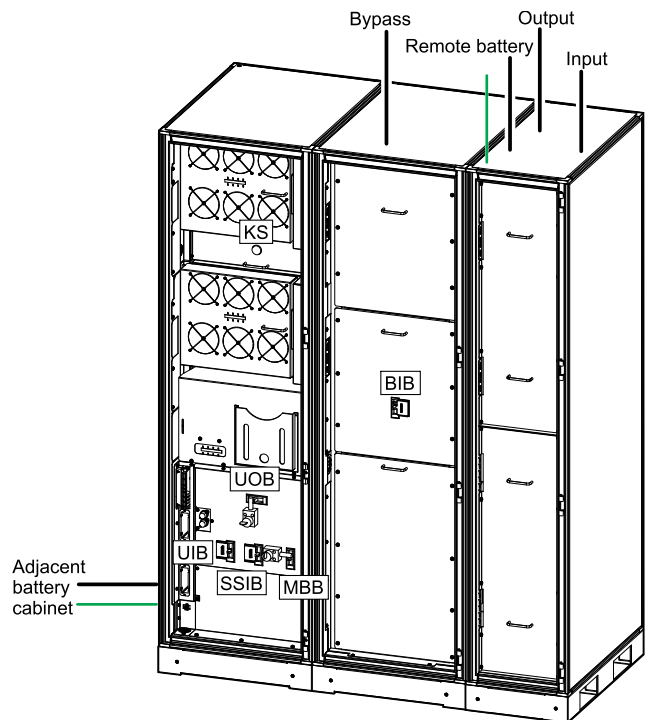

75–100 kVA UPS – Single Mains (100 kVA UPS Shown)

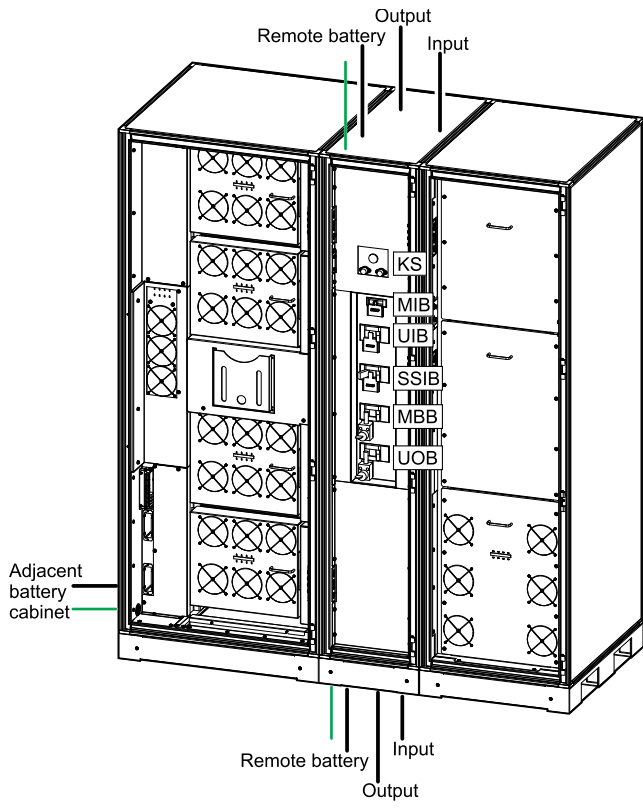

75–100 kVA UPS – Dual Mains (100 kVA UPS Shown)

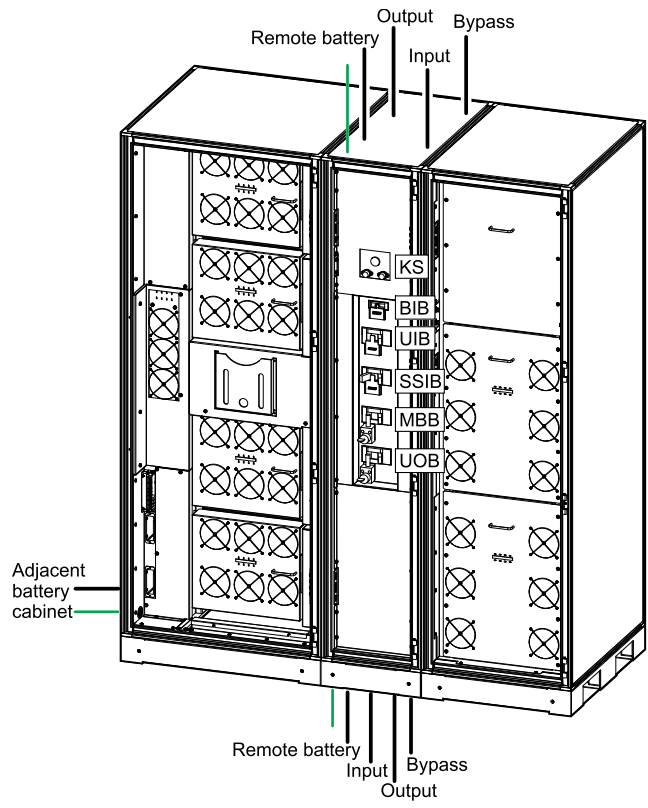



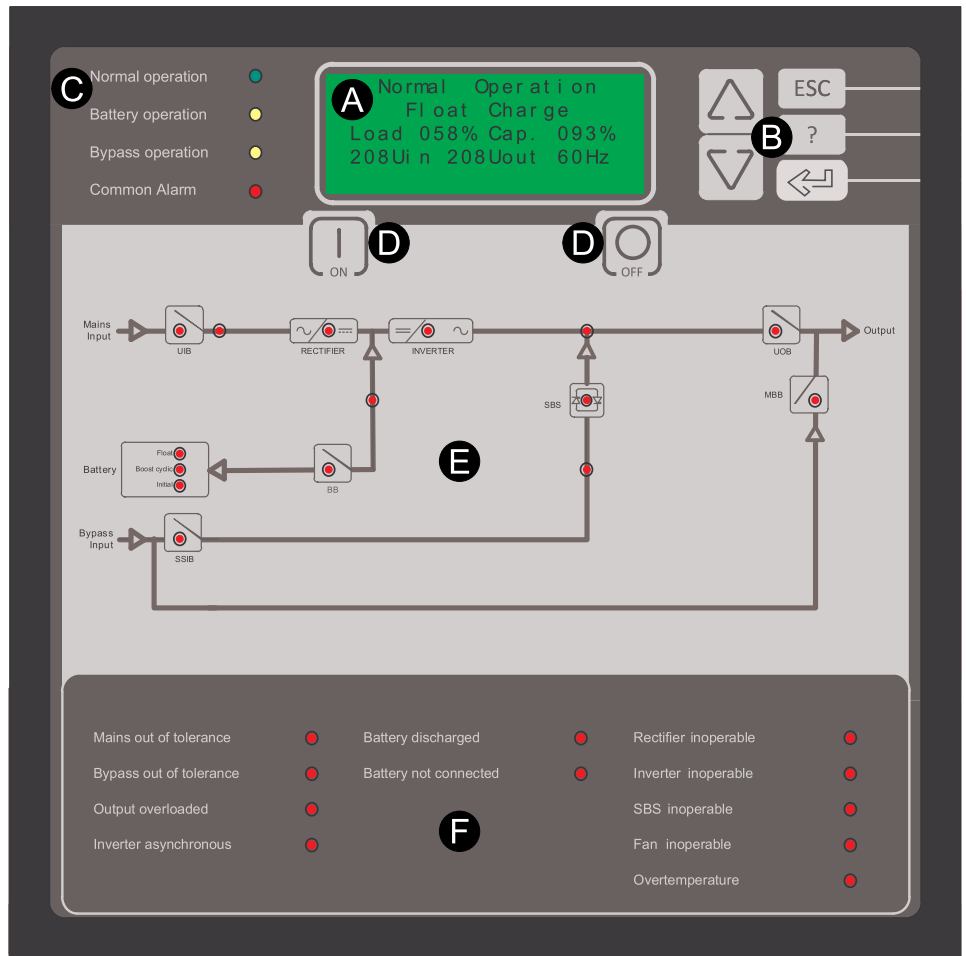

User Interface

User Interface on the UPS Cabinet



- A. Display
- B. Display navigation keys
- C. UPS status LEDs that show the current operation mode of the UPS
- D. ON and OFF buttons
- E. Mimic diagram that shows the power flow of the UPS
- F. Alarm LEDs. See *Alarm LEDs, page 47*.

Display Navigation Keys

	Use the ENTER key to enter the main menu, submenus, and confirm/save settings.
	Use the ESC key to return to a higher level menu.
	Use the UP key to select a submenu or to change a setting upwards.
	Use the DOWN key to select a submenu or to change a setting downwards.
	Use the HELP key to access help information about a menu point.

UPS Status LEDs

Normal operation LED	Green	The load is supplied by the input source.
Battery operation LED	Yellow	The load is supplied by the batteries.
Bypass operation LED	Yellow	The load is supplied by the bypass source.
Common Alarm LED	Red	An alarm exists in the UPS system.

Mimic Diagram

NOTE: The mimic diagram for 25–100 kVA UPS without transformer shows dual mains, but the UPS can be dual or single mains.

Mimic Diagram for 25–100 kVA UPS without Transformer

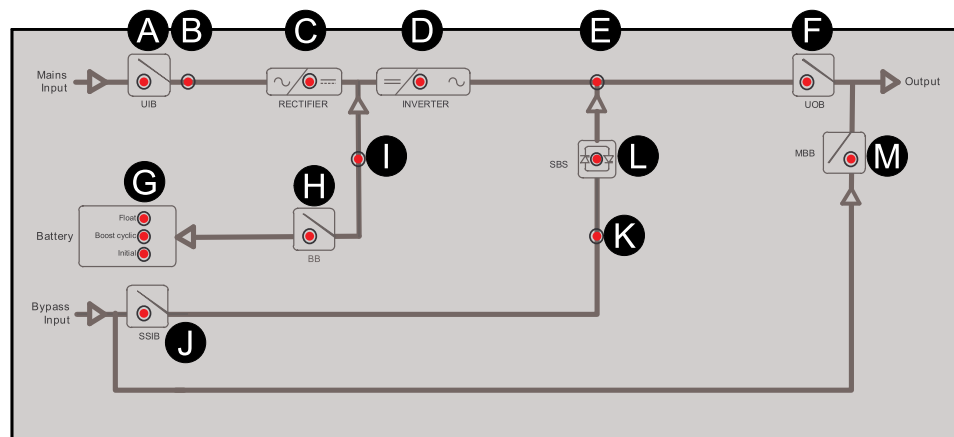

Mimic Diagram for 25–50 kVA UPS with Transformer for Single Mains

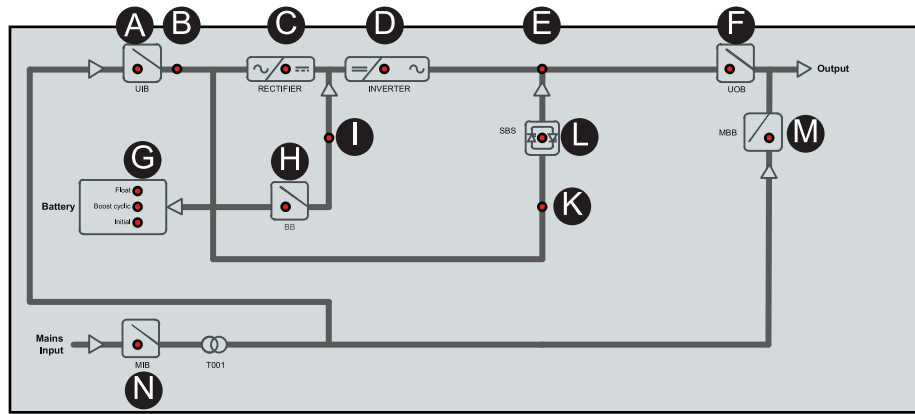

Mimic Diagram for 75–100 kVA UPS with Transformer for Single Mains

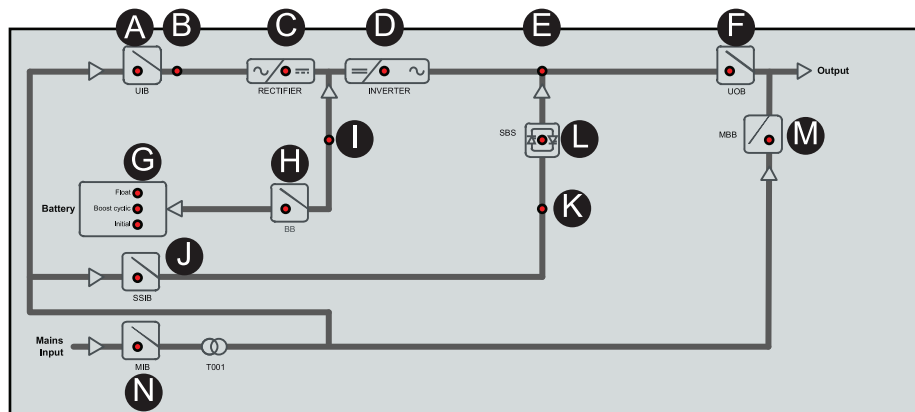

Mimic Diagram for 25–100 kVA UPS with Transformer for Dual Mains

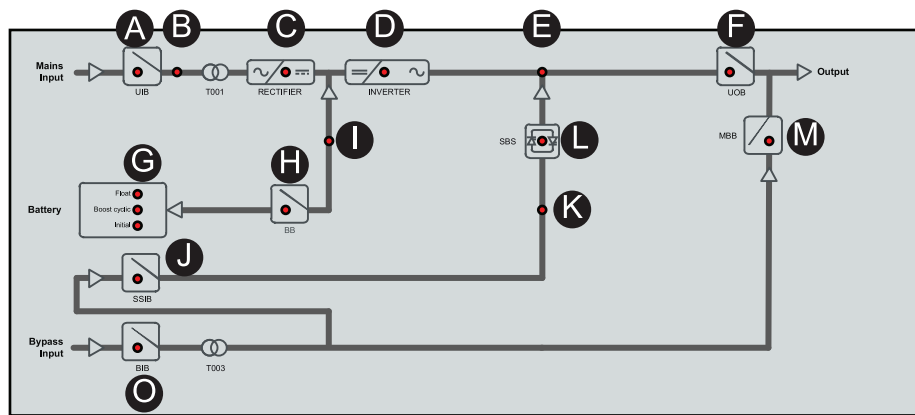

Position	LED color	Description
A	Green	The unit input breaker UIB is closed (ON)
	Red	The unit input breaker UIB is open (OFF)
B	Green	The mains voltage is within range
	Red	The mains voltage is out of range
C	Green	The rectifier is ON
	Orange	At least one rectifier is inoperable
	Red	The rectifier is inoperable
D	Green	The inverter is ON

Position	LED color	Description
	Orange	At least one inverter is inoperable
	Red	The inverter is inoperable
E	Green	The output voltage is within range
	Red	The output voltage is out of range
F	Green	The unit output breaker UOB is closed (ON)
	Red	The unit output breaker UOB is open (OFF)
G	yellow	Float: The battery is charged in float charge mode
	yellow	Boost cyclic: The battery is charged in boost charge mode or at cyclic charge level mode
	yellow	Initial: The battery is charged in initial charge mode
H	Green	The battery breaker BB is closed (ON)
	Red	The battery breaker BB is open (OFF)
I	Green	The battery voltage is within range
	Red	The battery voltage is out of range
J	Green	The static switch input breaker SSIB is closed (ON)
	Red	The static switch input breaker SSIB is open (OFF)
K	Green	The bypass voltage is within range
	Red	The bypass voltage is out of range
L	Green	The static bypass switch is ON
	Orange	The static bypass switch is independently switched on
	Red	The static bypass switch is inoperable
M	Green	The maintenance bypass breaker MBB is closed (ON)
	Red	The maintenance bypass breaker MBB is open (OFF)
N	Green	The mains input breaker MIB is closed (ON)
	Red	The mains input breaker MIB is open (OFF)
O	Green	The bypass input breaker BIB is closed (ON)
	Red	The bypass input breaker BIB is open (OFF)

Display

In normal operation with no alarms present, the display will show the overview screen with the system operation mode, operation information, and measurements.

NOTE: If the advanced battery monitoring (ABM) function is not available, the overview screen will not show calculated runtime or capacity.

Overview Screen in Standby Operation

Standby

The UPS output is turned OFF.

Overview Screen in Normal Operation

```
Normal Operation
Float Charge
Load 058% Cap. 093%
xxxUin xxxUout xxHz
```

The second line shows the battery charge mode: **Float Charge**, **Boost Charge**, **Initial Charge**, or **Cyclic Charge**.

Overview Screen in Battery Operation

```
Battery Operation
Runtime: 02h 42min
Load 058% Cap. 093%
xxxUin xxxUout xxHz
```

The calculated remaining runtime for the load percentage and the battery charge is shown on the second line if advanced battery monitoring (ABM) is set up. If an ABM test or a discharge test is running this is indicated in the second line. See *Perform Advanced Battery Monitoring (ABM) Test*, page 37 and *Perform Discharge Test*, page 38.

Overview Screen in Temporary Static Bypass Operation

```
Temporary Static
Bypass Operation
Load 058% Cap. 093%
xxxUin xxxUout xxHz
```

Overview Screen in Requested Static Bypass Operation

```
Requested Static
Bypass Operation
Load 058% Cap. 093%
xxxUin xxxUout xxHz
```

Overview Screen in ECO Mode

```
ECO mode
Float charge
Load 058% Cap. 093%
xxxUin xxxUout xxHz
```

Overview Screen in Maintenance Bypass Operation

```
Manual Bypass
Static Bypass
Load 058% Cap. 093%
xxxUin xxxUout xxHz
```

The second line indicates the state of the isolated system: **Standby**, **Normal Operation**, **Battery Operation**, **Static Bypass Operation**. Input voltage, output voltage, and output frequency are not shown in maintenance bypass operation.

Main Menu and Navigation

From the main menu it is possible to configure and monitor the system through the submenus: **System Status**, **System Control**, **Event Logging**, **Settings**, **Diagnosis**, and **Configuration**. Use the UP/ DOWN and the ENTER display navigation keys to navigate through the menus. Press the ESC key to return to a

previous menu. Press the HELP key to access help information about a menu point.

Menu Tree

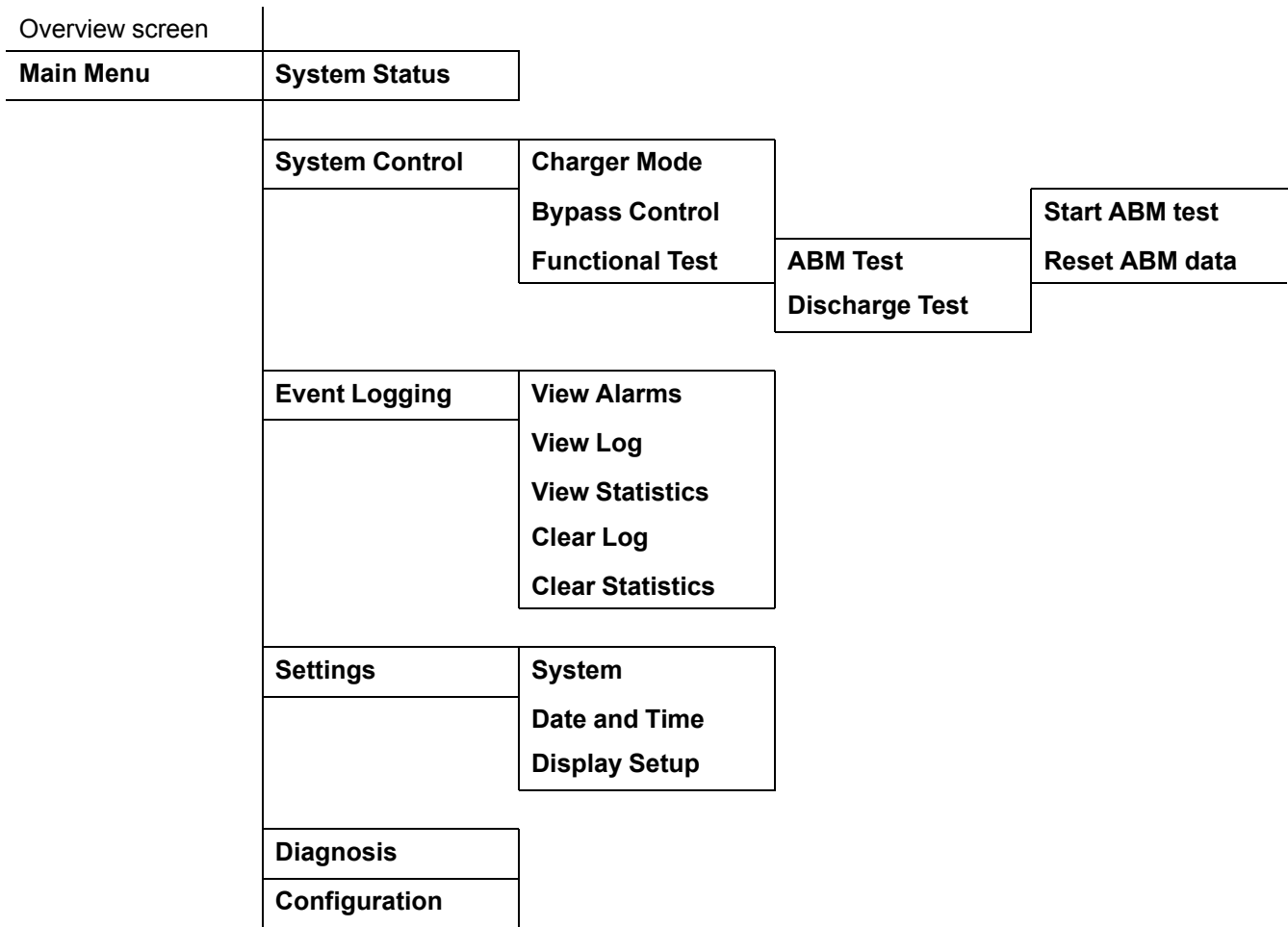

View System Status

1. From the **Main Menu**, select **System Status** using the UP/DOWN keys and the ENTER key.
2. Use the UP/DOWN keys to browse through the different measurement screens.

Ø	Uin	Ubyp	Uout
1	202.2	208.5	208.5
2	202.3	208.4	208.1
3	202.0	208.4	208.7

- Input voltages: phase to phase
- Bypass voltages (only displayed for dual mains with bypass transformer): phase to phase
- Output voltages: phase to phase

Ø	Iin	Ibyp	Iout
1	025.5	000.0	025.1
2	024.3	000.0	024.0
3	025.0	000.0	024.1

- Input current per phase
- Bypass current per phase (only displayed for dual mains with bypass transformer)
- Output current per phase

```

Out  kW    kVA    PF
1   017.3  019.4  096.5C
2   020.3  020.3  1.00
3   016.7  018.7  0.81I

```

- Real power on output
- Apparent power on output
- Power factor (cos phi) on output. **C** indicates capacitive load and **I** indicates inductive load.

```

Fin    Fbyp    Fout
60.1   60.0    60.0
Load:      058.4kVA
          055.2kW

```

- Input, bypass, and output frequencies
- Total apparent output power
- Total active output power

```

Bat Voltage: 439.2V
Bat Current:+005.3A
Bat Cap.:   098 %
Runtime: 01h 37min

```

- Battery voltage
- Battery current (positive = charging, negative = discharging)
- Actual battery charge in % of installed capacity
- Calculated runtime for the actual load and battery charge

```

Temperatures
Batt Temp:    028°C
My Sensor 2:  024°C
My Sensor 3:  036°C

```

- Battery cabinet temperature
- Sensor temperature (optional)
- Sensor temperature (optional)

```

Total system status
Load:          058.4kVA
              054.3kW
Load-%:        073.0 %

```

In a redundant system configuration:

- Total apparent output power
- Total active output power
- Total output power in percent of system rating

```

Total system status
UPS is master
UPS availability:
  1 of 2

```

In a redundant system configuration:

- This system is isolated, the master or slave
- Number of available systems

View System Configuration

1. From the **Main Menu**, select **Configuration** using the UP/DOWN keys and the ENTER key.
2. Use the UP/DOWN keys to browse through the system configuration screens. Here you can see information about the system configuration.

```

Type:    PXC-UL
Conf.:   Redundant
UPS:     2 of 2↓

```

- System type
- System configuration: **Single** or **Redundant**
- UPS number

Inp.	Byp.	Out.	↑
3x208V	3x208V	3x208V	
0058A	0058A	0174A	
T001	T003	T002	↓

- Nominal voltages on input, bypass, and output
- Nominal currents on input, bypass, and output
- Installed transformers in the system (optional)

Out. Freq.:	60Hz	↑
Out. Power:	050kVA	

↓

- System output frequency
- Nominal system output power

Alarm Thresholds:	↑
Load:	050 kVA
Runtime:	00h 20min
Bat. Temp.:	25 °C

- Overload alarm threshold
- Remaining battery runtime threshold
- Battery temperature threshold

Operation

Operation Modes

Normal Operation

During normal operation, the UPS supports the load with conditioned power. While the UPS is in normal operation, the status LED **Normal operation** is green.

Battery Operation

If the utility/mains supply becomes unavailable or outside specified limits, the UPS transfers to battery operation and supports the load with conditioned power from the DC source. While the UPS system is in battery operation, the status LED **Battery operation** is yellow.

Temporary Static Bypass Operation

The UPS is in temporary static bypass following a command from the UPS system. During temporary static bypass operation, the load is supplied by the bypass source. If there is an interruption to the utility/mains power supply during temporary static bypass operation, the system will transfer to battery operation. The load may experience a short duration interruption of power (4 to 8 ms) during this transfer. While the UPS system is in temporary static bypass operation, the status LED **Bypass operation** is yellow.

Requested Static Bypass Operation

The UPS can be transferred to requested static bypass operation following a command from the display. During static bypass operation, the load is supplied from the bypass source. If there is an interruption to the utility/mains power supply during requested static bypass operation, the system will transfer to battery operation. The load may experience a short duration interruption of power (4 to 8 ms) during this transfer. While the UPS system is in requested static bypass, the status LED **Bypass operation** is yellow.

ECO Mode

The UPS can be transferred to ECO mode with a command from the display or when ECO mode is enabled. The system will automatically switch to ECO mode after the system has been running for one minute in normal operation and the bypass voltage quality is within the acceptable limits. ECO mode will transfer the system to static bypass operation. In this operation mode the total system efficiency is increased. The load is supplied from the bypass source. To avoid interruptions during the transfer, the voltage, frequency and phase relation of the UPS system must be synchronized to the bypass source. The UPS will transfer to normal or battery operation if the bypass source becomes unavailable or if the bypass voltage quality drops below the acceptable limits. While the UPS system is in ECO mode, the status LED **Bypass operation** is yellow.

Maintenance Bypass Operation

In maintenance bypass operation, the load is supplied by unconditioned power from the bypass input via the maintenance bypass breaker (MBB). The batteries are not available as an alternate power source in maintenance bypass operation.

DANGER

HAZARD OF ELECTRIC SHOCK, EXPLOSION, OR ARC FLASH

The UPS with transformer in maintenance bypass operation still contain energized components in both the UPS cabinet and the transformer cabinet (if present). All sources to the UPS and transformer must be shut off before any work can be carried out on the units. The load will not be supported.

Failure to follow these instructions will result in death or serious injury.

Operation Procedures

Turn on the UPS

1. Press the **ON** button on the display.

Turn off the UPS

1. Press the **ON** and the **OFF** buttons simultaneously on the display. The UPS will shut down with no voltage on the output.

⚠ DANGER
HAZARD OF ELECTRIC SHOCK, EXPLOSION, OR ARC FLASH
After this operation, power will still be present on the power connection terminals. Ensure that the protection covers are installed.
Failure to follow these instructions will result in death or serious injury.

Transfer from Normal Operation to ECO Mode

NOTE: This menu is only available if ECO mode is enabled.

1. From the **Main Menu**, select **System Control > Bypass Control** using the UP/DOWN keys and the ENTER key.

```
Confirm action:
UPS into ECO Mode
NO, Abort
▶YES, UPS into ECO Mode
```

2. Select **YES, UPS into ECO Mode** to transfer to ECO mode. The following message will appear on the display:

```
The load is supplied via the static bypass switch
```

3. After the transfer to ECO mode is complete, press the ESC key.

Transfer from ECO Mode to Normal Operation

NOTE: This menu is only available if ECO mode is enabled.

1. From the **Main Menu**, select **System Control > Bypass Control** using the UP/DOWN keys and the ENTER key.
2. Select **YES, UPS out of ECO Mode** to transfer to normal operation.

```
Confirm action:
UPS out of ECO Mode
NO, Abort
▶YES, UPS out of ECO Mode
```

Transfer from Normal Operation to Requested Static Bypass Operation

NOTE: This menu is only available if **ECO Mode** is disabled.

1. From the **Main Menu**, select **System Control > Bypass Control** using the UP/DOWN keys and the ENTER key.

```
Confirm action:
UPS into Bypass
NO, Abort
▶YES, UPS into Bypass
```

2. Select **YES, UPS into Bypass** to transfer to requested static bypass operation. The following message will appear on the display:

```
The load is supplied via the static bypass switch
```

3. After the transfer to requested static bypass operation is complete, press the ESC key.

Transfer from Requested Static Bypass Operation to Normal Operation

NOTE: This menu is only available if ECO mode is disabled.

1. From the **Main Menu**, select **System Control > Bypass Control** using the UP/DOWN keys and the ENTER key.
2. Select **YES, UPS out of Bypass** to transfer to normal operation.

```
Confirm action:
UPS out of Bypass
NO, Abort
▶YES, UPS out of Bypass
```

Transfer from Normal Operation to Maintenance Bypass Operation

⚠ DANGER

HAZARD OF ELECTRIC SHOCK, EXPLOSION, OR ARC FLASH

The UPS with transformer in maintenance bypass operation still contains energized components in both the UPS cabinet and the transformer cabinet (if present). All sources to the UPS and transformer(s) must be shut off before any work can be carried out on the units. The load will not be supported.

Failure to follow these instructions will result in death or serious injury.

1. From the **Main Menu**, select **System Control > Bypass Control** using the UP/DOWN keys and the ENTER key.

2.
 - **With ECO mode enabled:** Select **YES, UPS into ECO Mode** to transfer to bypass operation. This action releases the key from the kirk key solenoid interlock.

```
Confirm action:
UPS into ECO Mode
NO, Abort
▶YES, UPS into ECO Mode
```

- **With ECO mode disabled:** Select **YES, UPS into Bypass** to transfer to bypass operation. This action releases the key from the kirk key solenoid interlock.

```
Confirm action:
UPS into Bypass
NO, Abort
▶YES, UPS into Bypass
```

3. Unlock and remove the key from the kirk key solenoid interlock KS.
4. Insert the key into the maintenance bypass breaker MBB. Unlock and close the maintenance bypass breaker MBB. The key is now trapped.
5. Open the unit output breaker UOB and lock the breaker in this position with its key. Remove the key.
6. Insert the key into the kirk key solenoid interlock KS and lock it.
7. Press the ON and OFF buttons simultaneously on the display to turn OFF the UPS.
8. Open the static switch input breaker SSIB (only in configurations where SSIB is present).
9. Open the unit input breaker UIB.
10. Open the battery breaker BB.
The UPS is now in maintenance bypass operation.

Transfer from Maintenance Bypass Operation to Normal Operation

1. Close the unit input breaker UIB.
2. Close the static switch input breaker SSIB (only in configurations where SSIB is present).
3. Press the ON button on the display to turn on the UPS.
4. Close the battery breaker BB.
5. From the **Main Menu**, select **System Control > Bypass Control** using the UP/DOWN keys and the ENTER key.

6.

- **With ECO mode enabled:** Select **YES, UPS into ECO Mode** to transfer to bypass operation.

```
Confirm action:
UPS into ECO Mode
NO, Abort
▶YES, UPS into ECO Mode
```

- **With ECO mode disabled:** Select **YES, UPS into Bypass** to transfer to bypass operation.

```
Confirm action:
UPS into Bypass
NO, Abort
▶YES, UPS into Bypass
```

The following message will appear on the display:

```
The load is supplied via the static bypass switch
```

- Unlock and remove the key from the kirk key solenoid interlock KS.
- Insert the key into the unit output breaker UOB. Unlock and close the unit output breaker UOB. The key is now trapped.
- Open the maintenance bypass breaker MBB and lock the breaker in this position with its key. Remove the key.
- Insert the key into the kirk key solenoid interlock KS and lock it.
- From the **Main Menu**, select **System Control > Bypass Control** using the UP/DOWN keys and the ENTER key.

12.

- **With ECO mode enabled:** Select **YES, UPS out of ECO Mode** to transfer to normal operation.

```
Confirm action:
UPS out of ECO Mode
NO, Abort
▶YES, UPS out of ECO Mode
```

- **With ECO mode disabled:** Select **YES, UPS out of Bypass** to transfer to normal operation.

```
Confirm action:
UPS out of Bypass
NO, Abort
▶YES, UPS out of Bypass
```

The UPS is now in normal operation.

Transfer from Normal Operation or ECO Mode to Maintenance Bypass Operation – Redundant Parallel UPS System N+1

⚠ DANGER

HAZARD OF ELECTRIC SHOCK, EXPLOSION, OR ARC FLASH

The UPS with transformer in maintenance bypass operation still contains energized components in both the UPS cabinet and the transformer cabinet (if present). All sources to the UPS and transformer(s) must be shut off before any work can be carried out on the units. The load will not be supported.

Failure to follow these instructions will result in death or serious injury.

NOTE: The following procedures apply to both UPS1 and UPS2 in parallel.

1. On UPS1: From the **Main Menu**, select **System Control > Bypass Control** using the UP/DOWN keys and the ENTER key.
If the UPS is running in ECO mode, proceed to step 3.
2. If the unit is running in normal operation, select **YES, UPS into Bypass** to transfer to bypass operation. All UPS units in the parallel system will now transfer to static bypass operation. This action releases the key from the kirk key solenoid interlock KS of UPS1 and UPS2.

```
Confirm action:  
UPS into Bypass  
NO, Abort  
▶YES, UPS into Bypass
```

3. Perform the following steps on both UPS1 and UPS2:
 - a. Unlock and remove the key from the kirk key solenoid interlock KS.
 - b. Insert the key into the maintenance bypass breaker MBB. Unlock and close the maintenance bypass breaker MBB. The key is now trapped.
 - c. Open the unit output breaker UOB and lock the breaker in this position with its key. Remove the key.
 - d. Insert the key into the kirk key solenoid interlock KS and lock it.
 - e. Press the ON and OFF buttons simultaneously on the display to turn OFF the UPS.
 - f. Open the static switch input breaker SSIB (only in configurations where SSIB is present).
 - g. Open the battery breaker BB.
 - h. Open the unit input breaker UIB.

The UPS system is now in maintenance bypass operation.

Transfer from Maintenance Bypass Operation to Normal Operation or ECO Mode – Redundant Parallel UPS System N+1

1. Perform the following steps on both UPS1 and UPS2.
 - a. Close the unit input breaker UIB.
 - b. Close the static switch input breaker SSIB (only in configurations where SSIB is present).
 - c. Press the ON button on the display to turn on the UPS.
 - d. Close the battery breaker BB.

NOTE: If ECO mode is enabled, the UPSs will transfer to ECO mode 1 minute after the units have turned ON.
 - e. From the **Main Menu**, select **System Control > Bypass Control** using the UP/DOWN keys and the ENTER key.
 - f. If the units are running in normal operation, select **YES, UPS into Bypass**. This action releases the key from the kirk key solenoid interlock.

```

Confirm action:
UPS into Bypass
NO, Abort
▶YES, UPS into Bypass
  
```

The following message will appear on the display:

```

The load is supplied via the static bypass switch
  
```

- g. If ECO mode is enabled, verify that the units are running in ECO mode.
- h. Unlock and remove the key from the kirk key solenoid interlock KS.
 - i. Insert the key into the unit output breaker UOB. Unlock and close the unit output breaker UOB. The key is now trapped.
 - j. Open the maintenance bypass breaker MBB and lock the breaker in this position with its key. Remove the key.
 - k. Insert the key into the kirk key solenoid interlock KS and lock it.
2. From the **Main Menu** on one of the UPSs, select **System Control > Bypass Control** using the UP/DOWN keys and the ENTER key.
 - **With ECO mode enabled:** Select **YES, UPS out of ECO Mode** to transfer both UPSs to normal operation.

```

Confirm action:
UPS out of ECO Mode
NO, Abort
▶YES, UPS out of ECO Mode
  
```

- **With ECO mode disabled:** Select **YES, UPS out of Bypass** to transfer both UPSs to normal operation.

```

Confirm action:
UPS out of Bypass
NO, Abort
▶YES, UPS out of Bypass
  
```

The UPS system is now in normal operation.

View the Event Log

1. From the **Main Menu**, select **Event Logging > View Log** using the UP/DOWN keys and the ENTER key. Wait a few seconds while the event log is being prepared.
2. Use the UP/DOWN keys to browse through the log entries. All system events and alarms are stored in this event log.

Clear the Event Log

1. From the **Main Menu**, select **Event Logging > Clear Log > YES, Clear Log** using the UP/DOWN keys and the ENTER key.

View the Alarms

1. From the **Main Menu**, select **Event Logging > View Alarms** using the UP/DOWN keys and the ENTER key. Wait a few seconds while the alarm list is being prepared.
2. Use the UP/DOWN keys to browse through the alarms present on the UPS system.

Example

```
Present Alarms:      ↓  
Bypass RMS not ok 123  
Output RMS not ok 034  
Inverter async. 456
```

View Diagnosis

1. From the **Main Menu**, select **Diagnosis** using the UP/DOWN keys and the ENTER key.
2. Use the UP/DOWN keys to browse through the diagnosis screens. Here you can see information about the input from the input contacts, internal measurements, and internal status.

```
Breaker status:
SSIB UOB MIB BB
OFF OFF OFF OFF
```

The state of the breakers in the system.

- **ON** or **OFF** for a breaker

```
Inputs status:      ↑
EPO                  :0
Force to Boost      :1
Block Boost/Init:1↓
```

The current state of the input contacts of the system.

- Three inputs on the external connection board 0P2553

```
Ø Urec Usbs Uinv↑
1 208.3 207.9 208.2
2 208.6 207.5 208.3
3 208.6 207.2 208.1↓
```

- Rectifier input voltage line-to-line measured after the input transformer
- Bypass voltage line-to-line measured after the bypass transformer
- Inverter output voltage line-to-line measured before the output transformer

```
U dc-bus: + 225.5V↑
           - 225.8V↓
```

DC-Bus positive and negative side voltages

```
Temperatures      ↑
T001: 123 °C
T002: 105 °C
T003: 042 °C↓
```

- Input transformer temperature (if installed)
- Output transformer temperature (if installed)
- Bypass transformer temperature (if installed)

```
LCM Status:↑
No alert pending ↓
```

- Life cycle monitoring (LCM) status screen

```
HMI FW: 03.00.00 ↑
DSP FW: 04.11.00
IF FW: 01.04.00
```

- Display firmware revision (**HMI**)
- Main controller firmware revision (**DSP**)
- Interface board firmware revision (**IF**)

View Statistics

1. From the **Main Menu**, select **Event Logging > View Statistics** using the UP/DOWN keys and the ENTER key.
2. Use the UP/DOWN keys to browse through the statistics available on the UPS.

```
023 Transfers->Bat.  
006 Transfers->Byp.  
004836hr Inv. Time  
024h 13min on Bat↓
```

- Number of transfers to battery operation
- Number of transfers to bypass operation
- Total time in inverter operation
- Total time in battery operation

```
Uin max: 227.6V↑  
Uin min: 189.9V  
Ubat max: 445.3V  
Ubat min: 391.2V↓
```

- The highest and lowest measured input voltages on mains and battery

```
Iin max: 056.3A↑  
Iout max: 055.4A
```

- The highest measured currents on mains and UPS output

```
Last discharge test↑  
Date: 21.07.2015  
Runtime: 0312 min  
Load: 040%-082%
```

- Data from the last **Discharge test**

Clear Statistics

1. From the **Main Menu**, select **Event Logging > Clear Statistics > YES, Clear Statistics** using the UP/DOWN keys and the ENTER key.

Configuration

Set the Date and Time

1. From the **Main Menu**, select **Settings > Date and time** using the UP/DOWN keys and the ENTER key. You can press the ESC key at any time to cancel the modification of the parameter values.

```
Date and Time:
Date: 21-Jul-2015
Time: 11:35:08
```

2. Press the ENTER key to start modifying the parameter values.

```
Date and Time:
Date: ↓21-Jul-2015
Time: 11:35:08
      SET
```

3. Press the UP/DOWN keys to modify the parameter values and press the ENTER key to confirm modification and move to the next parameter value.

```
Date and Time:
Date: 22↑Jul-2015
Time: 11:35:08
      SET
```

4. When you have modified all the parameter values, the cursor will point to **SET** – press the ENTER key to confirm and save the modified date and time values.

```
Date and Time:
Date: 22↑Jul-2015
Time: 11:35:08
      ►SET
```

Set Up the Display

1. From the **Main Menu**, select **Settings > Display Setup** using the UP/DOWN keys and the ENTER key. You can press the ESC key at any time to cancel the modification of the parameter values.

```
Display Setup:
Language: English
Contrast: 1
Beeper Volume: 3
```

2. Press the UP/DOWN keys to select a parameter to modify and press the ENTER key.

```
Display Setup:
►Language: English
Contrast: 1
Beeper Volume: 3
```

3. Press the UP/DOWN keys to modify the parameter values and press the ENTER key to save the modification and move to the next parameter value.

```
Display Setup:
↑Language: English
Contrast: 2
Beeper Volume: 1
```

4. When you have modified all the parameter values, press the ESC key return to a higher menu level.

Reset the Display Language to English

1. From the overview menu, press the ESC key ten times (within 10 seconds). The display language will now reset to English.

Set Auto Start, Auto Boost, LCM Alerts, and ECO Mode

1. From the **Main Menu**, select **Settings > System** using the UP/DOWN keys and the ENTER key. You can press the ESC key at any time to cancel the modification of the parameter values.

```
System:
▶Auto Start : On
Auto Boost : Off
LCM Alerts: On↓
```

```
System:↑
▶ECO Mode : On
```

2. Select **Auto Start**, **Auto Boost**, **LCM Alerts**, or **ECO Mode** using the UP/DOWN keys and the ENTER key.
3. Select **On** or **Off** using the UP/DOWN keys and the ENTER key to save the setting.

```
System:
↑Auto Start: On
Auto Boost: Off
LCM Alerts: On↓
```

```
System:↑
↑ECO Mode : On
```

The UPS will go to ECO mode one minute after turning on the inverter.

Set Battery Charge Mode

1. From the **Main Menu**, select **System Control > Charge mode** using the UP/DOWN keys and the ENTER key.

```
Charge mode:
  Float
Ubat: 440.3V  438 V
Ibat:+004.2A  007.2A
```

```
Charge mode:
  Cyclic
Ubat: 440.3V  438 V
Ibat:+004.2A  007.2A↓
```

Cyclic charge mode has a second page that shows the configured period and charge time.

2. Press the ENTER key to start modifying the parameter values.
3. Press the UP/DOWN keys to modify the parameter values and press the ENTER key to confirm modification.

```
Charge mode:
↓ Float
Ubat: 440.3V  438 V
Ibat:+004.2A  007.2A
```

Maintenance

Replace the Filters

1. Pull the top of the air grid free of the cabinet.

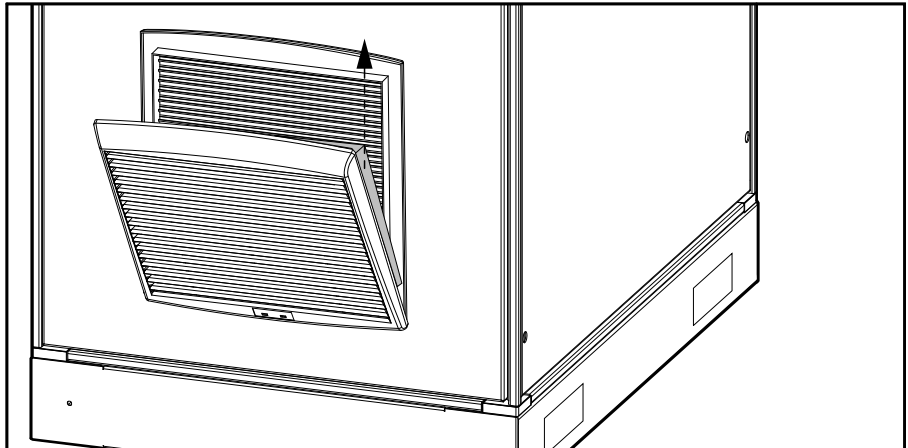

2. Replace the air filter.
3. Push the air grid back into position.

Perform LED and Display Test

1. From the overview menu, press twice on the UP key (within two seconds).

All status, mimic diagram, and alarm LEDs will be activated. All segments on the display will be switched on. When the test is complete all LEDs will go back to normal function and the display returns to the overview menu.

Perform Advanced Battery Monitoring (ABM) Test

NOTE: Only available if advanced battery monitoring is set up.

This test detects weak or inoperable batteries, or determines the capacity and runtime estimation based on voltage and current (performed by Schneider Electric field service engineer during start-up of the UPS). The test initiates a capacity discharge of 10%. During this test the battery voltage is monitored. If the battery voltage drops below the battery weak level, the battery weak alarm is generated. If the voltage drops below the battery inoperable level, the battery inoperable alarm is generated. The test then stops immediately. Both alarms are stored and can only be reset by selecting **System Control > Functional Test > ABM Test > Reset ABM data**. The **ABM Test** can only be started if the battery is at least 50% charged.

1. From the **Main Menu**, select **System Control > Functional Test > ABM Test > Start ABM test** using the UP/DOWN keys and the ENTER key.

```
ABM test:
▶ Start ABM test
Reset ABM data
```

2. Select **YES, Start test** in the next menu.

```
Confirm action:
Start ABM test
NO, Abort
▶YES, Start test
```

During the ABM test, the overview menu shows the following:

```
Battery Operation
ABM test
Load 058% Cap. 093%
208Uin 208Uout 60Hz
```

NOTE: If automatic testing is selected in the system settings, the test is executed (if possible) automatically. After the test the system returns to the former operation mode.

Perform Discharge Test

The discharge test initiates a complete discharge of the battery down to the low battery warning level or to the voltage which stops the test (defined in the system settings).

NOTE: If the ABM is not available, no values for **Runtime** or **Capacity** are displayed.

1. From the **Main Menu**, select **System Control > Functional Test > Discharge Test** using the UP/DOWN keys and the ENTER key.

```
Functional test:
▶Discharge test
ABM test
```

2. Select **YES, Start test** in the next menu.

```
Confirm action:
Start discharge test
NO, Abort
▶YES, Start test
```

During the discharge test, the overview menu shows the following:

```
Battery Operation
Discharge test
Load xxx% Cap. xxx%
xxxUin xxxUout xxHz
```

NOTE: After the test the system returns to the former operation mode. The data of the last discharge test are shown in the menu **View Statistic**.

Life Cycle Monitoring (LCM)

The life cycle monitoring (LCM) function provides UPS preventive maintenance advice.

The display shows the following messages:

LCM Alerts	Corrective action
Start-up reminder	Contact Schneider Electric for start-up.
Fan module replacement recommended	Technical check needed.
Battery replacement recommended	Technical check needed.
Power module replacement recommended	Technical check needed.
Air filter replacement recommended	Replace the air filters.
Warranty expired	The warranty on the product has expired.

Troubleshooting

Status and Event Messages

The following table lists pop-up messages that can appear on the display:

Message number	Message text	Pop-up text	Description	Corrective action
2	System configuration	System configuration not OK	System configuration not OK. Hardware inoperable or wrong configuration file loaded.	Contact Schneider Electric.
186	Bat. temp. warning	Battery temperature has exceeded upper limit	The battery temperature is above the configured warning level.	Check the air inlet.
				Check the ambient temperature.
				Check the charge current.
				Check the state of the battery.
266	Output voltage	High output voltage	The UPS output voltage (RMS) is above the configured voltage level.	Contact Schneider Electric.
269	Overload	UPS overloaded	The UPS output is overloaded (>105%).	Reduce the load.
304	High Battery voltage	Battery voltage too high	The battery voltage is above the configured high battery voltage warning level. This warning is suppressed in battery operation.	Contact Schneider Electric.
306	Battery discharged	Inverter shutdown due to low Battery	The battery voltage is below the configured low battery voltage shutdown level.	Charge the battery. If the battery does not charge, contact Schneider Electric.
				Contact Schneider Electric.
312	Battery weak	Battery weak	The advanced battery monitoring test has detected a weak battery.	Charge the battery. If the battery does not charge, contact Schneider Electric.
313	Battery inoperable	Battery inoperable	The advanced battery monitoring test has detected an inoperable battery.	Contact Schneider Electric.
341	BB Battery Breaker	BB open / BB closed	The battery breaker BB is open/closed.	-
351	ABUS termination incorrect	ABUS termination incorrect	The ABUS wiring is disconnected or the ABUS termination is incorrect.	Contact Schneider Electric.
371	No parallel master	No Master present in the parallel system	No master is present in the redundant system.	Contact Schneider Electric.
375	Redundancy alarm	Loss of Parallel Redundancy	At least one UPS is isolated or turned off. In this case the redundancy operation is not assured.	-
397	PBUS1 com inoperable	Parallel bus communication on cable 1 inoperable	The internal or external PBUS1 wiring (parallel bus) is disconnected or the PBUS1 termination is incorrect.	Contact Schneider Electric.
398	PBUS2 com inoperable	Parallel bus communication on cable 2 inoperable	The internal or external PBUS2 wiring (parallel bus) is disconnected or the PBUS2 termination is incorrect.	Contact Schneider Electric.
440	EPO active	EPO activated	The digital input "emergency power off (EPO)" is activated (contact open) or the EPO wiring is disconnected.	Check the EPO switch. If the EPO is OFF, contact Schneider Electric.
447	Internal inoperable state	Internal inoperable state detected	An internal inoperable state was detected.	Contact Schneider Electric.
803	Static Bypass Switch inoperable	Static Bypass Switch inoperable	The communication to the static bypass switch is not working or DC is detected during requested static bypass operation.	Contact Schneider Electric.

Mes- sage number	Message text	Pop-up text	Description	Corrective action
814	Overtemperature in PM or Transformers	Overtemperature in PM or Transformers	The UPS measures a temperature above the threshold level in one of the power modules or in one of the transformers.	Check the air inlet and the air filters.
				Check the ambient temperature.
				Check the output load.
				Contact Schneider Electric.
825	Fan inoperable	Fan inoperable	One of the transformer-, static bypass switch- or power module fans is inoperable.	Contact Schneider Electric.
826	Battery earth fault	Battery earth fault	The UPS measures a battery earth fault.	Check the battery wiring.
830	Rectifier inoperable	Rectifier inoperable	The PFC rectifier or the charger is inoperable.	Contact Schneider Electric.
831	Inverter inoperable	Inverter inoperable	The inverter is inoperable.	Contact Schneider Electric.
HMI_1	ABUS communication inoperable	ABUS communication inoperable	Communication via ABUS does not work.	Contact Schneider Electric.
HMI_2	ABUS supply missing	ABUS supply missing	The SELV4 supply of the HMI is missing.	Contact Schneider Electric.
HMI_3	No more space for configurations in HMI FLASH memory	No more space for configurations in HMI FLASH memory	The HMI Flash memory does not offer enough free space to save the configuration change.	Contact Schneider Electric.
HMI_4	HMI SRAM is inoperable	HMI SRAM is inoperable	The external SRAM on the HMI was detected to be inoperable.	Contact Schneider Electric.
HMI_5	HMI code memory checksum invalid	HMI code memory checksum invalid	The HMI firmware detected an invalid code memory CRC.	Contact Schneider Electric.

Log Events

The following table lists events that can appear on the display log and some assigned to LEDs on the user interface:

Message number	Log	Description	Corrective action
11	Standby	The system is in standby.	-
15	Battery operation	The system is in battery operation.	-
16	Normal operation	The system is in normal operation.	-
17	Requested Static bypass	The system is in requested static bypass operation due to a user request.	-
18	Temporary Static bypass	The system is in temporary static bypass operation due to a problem in the system.	Check the event log to find out why the system has switched to static bypass operation.
			Contact Schneider Electric.
40	Charger OFF	The battery charger has been set to OFF state. The batteries are not charged in this state.	-
41	Float charge	The battery charger has been set to Float charge state. The batteries are charged with the configured float charge voltage.	-
42	Boost charge	The battery charger has been set to Boost charge mode. The batteries are charged with the configured boost charge voltage.	-
43	Initial charge	The battery charger has been set to Initial charge mode. The batteries are charged with the configured initial charge voltage.	-
44	Cyclic charge	The battery charger has been set to Cyclic charge mode. The batteries are charged with the configured cyclic charge voltage.	-
45	Boost / Initial-Charge blocked	The digital input to block boost/initial charge is activated.	-
102	PFC inoperable	The rectifier part of the power module is not working.	Contact Schneider Electric.
110	Charger inoperable	The charger part of the power module is not working.	Contact Schneider Electric.
132	Inverter inoperable	The inverter part of the power module is not working.	Contact Schneider Electric.
146	Inverter asynchronous	The UPS is unable to synchronize to the bypass source.	Check that the inverter is on.
			Check the bypass source quality (voltage, frequency).
			Contact Schneider Electric.
161	SBS ON	The system is in static bypass operation. The bypass supplies the load (temporary or requested static bypass operation).	-
162	SBS inoperable	The static bypass switch is not energized, the communication wiring from the UPS controller to the static bypass switch controller is disconnected or the static bypass switch controller is inoperable.	Contact Schneider Electric.
163	SBS Independent fired	The static bypass switch is no longer controlled by the UPS controller and is locked in the on state.	Contact Schneider Electric.
164	SBS DC detected	DC content detected in requested static bypass operation.	Contact Schneider Electric.

Message number	Log	Description	Corrective action
169	MBB closed	The maintenance bypass breaker MBB is closed.	-
181	PM Temperature warning	The power module temperature is above 90 °C.	Check the air inlet of the UPS.
			Check the ambient temperature.
			Reduce the load.
			Contact Schneider Electric.
182	PM Overtemperature	The power module temperature is above 100 °C (delay 60 seconds). The inverter is shut down immediately.	Check the air inlet of the UPS.
			Check the ambient temperature.
			Reduce the load.
			Contact Schneider Electric.
186	Battery temperature warning	The battery temperature is above the configured warning level.	Check the air inlet.
			Check the ambient temperature.
			Contact Schneider Electric.
187	Battery temperature shutdown	The battery temperature is above the configured shutdown level. The battery charger switches off.	Check the air inlet.
			Check the ambient temperature.
			Contact Schneider Electric.
189	Temperature 1 warning	The sensor, connected to the external connection board, measures a temperature above the configured warning level.	Contact Schneider Electric.
190	Temperature 2 warning	The sensor, connected to the external connection board, measures a temperature above the configured warning level.	Contact Schneider Electric.
191	Temperature 3 warning	The sensor, connected to the external connection board, measures a temperature above the configured warning level.	Contact Schneider Electric.
200	PM fan inoperable	One of the power module fans is inoperable.	Contact Schneider Electric.
201	SBS fan inoperable	One of the static bypass switch fans is inoperable.	Contact Schneider Electric.
202	Transformer fan inoperable	One of the transformer fans is inoperable (input transformer, output transformer or bypass transformer).	Contact Schneider Electric.
203	T001 Overtemperature	The input transformer temperature is above the configured threshold level. After 10 minutes, the rectifier is shut down and the system changes to battery operation.	Check the air inlet of the UPS.
			Check the ambient temperature.
			Reduce the battery charging current.
			Reduce the load.
			Contact Schneider Electric.
204	T002 Overtemperature	The output transformer temperature is above the configured threshold level. After 10 minutes, the system tries to change to static bypass operation within the next 2 minutes. If the change to static bypass operation is not possible due to bad bypass quality the inverter is shut down after these 2 minutes.	Check the air inlet of the UPS.
			Check the ambient temperature.
			Reduce the load.
			Contact Schneider Electric.
205	T003 Overtemperature	The bypass transformer temperature is above the threshold level.	Check the air inlet of the UPS.
			Check the ambient temperature.
			Reduce the load.
			Contact Schneider Electric.
206	T001 temperature sensor inoperable	The mains input transformer temperature sensor is not connected or shorted.	Contact Schneider Electric.

Message number	Log	Description	Corrective action
207	T002 temperature sensor inoperable	The output transformer temperature sensor is not connected or shorted.	Contact Schneider Electric.
208	T003 Temperature sensor inoperable	The bypass transformer temperature sensor is not connected or shorted.	Contact Schneider Electric.
220	Mains RMS not OK	The input voltage is out of the configured tolerance.	Check the quality of the input (voltage and frequency).
221	Mains input RMS not OK	The input voltage on primary side of the input transformer is out of the configured tolerance.	Check the quality of the input (voltage and frequency).
222	Mains FAST not OK	The input voltage is out of tolerance.	Check the quality of the input (voltage and frequency).
223	Mains frequency not OK	The input frequency is out of the configured tolerance.	Check the quality of the input (voltage and frequency).
224	Mains phase missing	A input input phase is missing.	Contact Schneider Electric.
225	Mains input phase missing	One phase of the input voltage on the primary side of the input transformer is missing.	Contact Schneider Electric.
228	Mains synch missing	The mains PFC rectifier is unable to synchronize to the input input.	Contact Schneider Electric.
229	Mains neutral missing	The input neutral is missing.	Contact Schneider Electric.
240	Bypass RMS not OK	The bypass voltage is out of the configured tolerance. The UPS is not able to transfer to static bypass operation.	Check the quality of the bypass (voltage and frequency).
241	Bypass input RMS not OK	The bypass mains voltage on the primary side of the bypass transformer is out of the configured tolerance.	Check the quality of the bypass (voltage and frequency).
242	Bypass FAST not OK	The bypass voltage is out of the configured tolerance. The UPS is unable to transfer to static bypass operation.	Check the quality of the bypass (voltage and frequency).
243	Bypass frequency not OK	The bypass frequency is out of the configured tolerance. The UPS is unable to transfer to static bypass operation.	Check the quality of the bypass (voltage and frequency).
244	Bypass phase missing	One phase of the bypass mains is missing.	Contact Schneider Electric.
245	Bypass input phase missing	One phase of the bypass voltage on the primary side of the transformer is missing.	Contact Schneider Electric.
260	Inverter output RMS not OK	The UPS output voltage is out of the configured tolerance.	Contact Schneider Electric.
261	Output RMS not OK	The output voltage on the secondary side of the output transformer is out of the configured tolerance.	Contact Schneider Electric.
262	Output FAST not OK	The UPS output voltage is out of the configured tolerance.	Contact Schneider Electric.
263	Output frequency not OK	The UPS output frequency is out of the configured tolerance.	Contact Schneider Electric.
264	Output phase missing	One phase of the output voltage on the secondary side of the transformer is missing.	Contact Schneider Electric.
267	High Load warning	The load is above the configured load alarm level.	Reduce the load.
268	Current limitation	The inverter current limiter is active.	Reduce the load.
269	Output overloaded	The UPS output is overloaded (>105%).	Reduce the load.
301	High Battery shutdown	The battery voltage is above the configured high battery voltage shutdown level. The charger is shut down.	Contact Schneider Electric.

Message number	Log	Description	Corrective action
304	High Battery warning	The battery voltage is above the configured high battery voltage warning level. This warning is suppressed in battery operation.	Contact Schneider Electric.
305	Battery discharged	The battery voltage is below the configured low battery voltage warning level.	Charge the battery. If the battery does not charge, contact Schneider Electric.
306	Low Battery shutdown	The battery voltage is below the configured low battery voltage shutdown level.	Charge the battery.
307	Battery earth fault positive	The UPS measures a positive battery earth fault.	Contact Schneider Electric.
308	Battery earth fault negative	The UPS measures a negative battery earth fault.	Contact Schneider Electric.
309	ABM test started	The advanced battery monitoring test has been started.	-
310	ABM test done	The advanced battery monitoring test has been completed.	-
311	ABM test aborted	The advanced battery monitoring test has been aborted.	-
312	Battery weak	The advanced battery monitoring test has detected a weak battery.	Charge the battery. If the battery does not charge, contact Schneider Electric.
313	Battery inoperable	The advanced battery monitoring test has detected an inoperable battery.	Contact Schneider Electric.
314	Low runtime warning	The battery runtime is less than 2 minutes above the configured warning level.	-
315	Low runtime alarm	The battery runtime is below the configured battery runtime level.	-
316	Discharge test started	The battery discharge test has been started.	-
317	Discharge test done	The battery discharge test has been completed.	-
318	Discharge test aborted	The battery discharge test has been aborted.	-
340	UIB open	The unit input breaker UIB is open.	-
341	BB open	The battery breaker BB is open.	-
349	SSIB open	The static switch input breaker SSIB is open.	-
342	UOB open	The unit output breaker UOB is open.	-
338	K401 open	The bypass backfeed contactor K401 is open.	-
351	ABUS termination incorrect	The ABUS wiring is disconnected or the ABUS termination is incorrect.	Contact Schneider Electric.
371	No parallel Master	No master is present in the redundant system.	Contact Schneider Electric.
374	Parallel load alarm	The actual load is too high for redundant operation. If one UPS switches OFF, the remaining systems would be overloaded.	Reduce the load. Check that all the UPSs are ON.
375	Redundancy alarm	At least one UPS is isolated or turned off. In this case the redundancy operation is not available.	Reduce the load. Check that all the UPSs are ON.
397	PBUS1 communication inoperable	The internal or external PBUS1 wiring (parallel bus) is disconnected or the PBUS1 termination is incorrect.	Contact Schneider Electric.
398	PBUS2 communication inoperable	The internal or external PBUS2 wiring (parallel bus) is disconnected or the PBUS2 termination is incorrect.	Contact Schneider Electric.

Message number	Log	Description	Corrective action
399	PBUS 1 termination incorrect	The internal or external PBUS1 wiring (parallel bus) is disconnected or the PBUS1 termination is incorrect.	Contact Schneider Electric.
400	PBUS 2 termination incorrect	The internal or external PBUS2 wiring (parallel bus) is disconnected or the PBUS2 termination is incorrect.	Contact Schneider Electric.
440	Emergency Power Off (EPO)	The digital input "emergency power off (EPO)" is activated (contact open) or the EPO wiring is disconnected.	Check the EPO switch. If the EPO is off, contact Schneider Electric.
447	Internal inoperable state	An internal inoperable state was detected.	Contact Schneider Electric.
448	SBS locked	The system has been locked in static bypass operation after eight unsuccessful tries to switch back to normal or battery operation.	Contact Schneider Electric.
663	Fan module replacement recommended	The life cycle monitoring recommends to replace the fan modules.	-
668	Battery replacement recommended	The life cycle monitoring recommends to replace the battery.	-
673	Power module replacement recommended	The life cycle monitoring recommends to replace the power modules.	-
678	Air filter replacement recommended	The life cycle monitoring recommends to replace the air filters.	-
683	Warranty expired	The warranty on the product has expired.	-
738	ECB- input 1	External connection board input 1 open / close	-
739	ECB- input 2	External connection board input 2 open / close	-
800	Common Alarm	There is at least one pending alert in the system.	Check alarm.
803	SBS inoperable	The communication to the static bypass switch is not working or DC is detected during requested static bypass operation.	Contact Schneider Electric.
807	Bypass out of tolerance	The bypass voltage is out of the configured tolerance, a phase is missing, there is an invalid phase rotation or the frequency is out of the configured tolerance.	-
808	Output out of tolerance	The output voltage or the frequency is out of configured tolerance.	Contact Schneider Electric.
812	Mains out of tolerance	The mains input voltage is out of the configured tolerance, a phase is missing, there is an invalid phase rotation or the frequency is out of the configured tolerance.	-
814	Overtemperature	The UPS measures a temperature above the threshold level in one of the power modules or in one of the transformers.	Check the air inlet and the air filters.
			Check the ambient temperature.
			Check the output load.
			Contact Schneider Electric.
823	Battery out of tolerance	The battery voltage is out of the configured tolerance or the battery runtime is too short.	Check if the UPS is in battery operation. If the UPS is not in battery operation, contact Schneider Electric.
825	Fan inoperable	One of the transformer-, static bypass switch- or power module fans is inoperable.	Contact Schneider Electric.
826	Battery earth fault	The UPS measures a battery earth fault.	Contact Schneider Electric.

Message number	Log	Description	Corrective action
830	Rectifier inoperable	The PFC rectifier or the charger is inoperable.	Contact Schneider Electric.
831	Inverter inoperable	The inverter is inoperable.	Contact Schneider Electric.

Alarm LEDs

The alarm LEDs are located on the user interface below the mimic diagram.

Alarm number	LED text	Description	Corrective action
146	Inverter asynchronous	The UPS is unable to synchronize to the bypass source.	Check that the inverter is ON.
			Check the bypass source quality (voltage, frequency).
			Contact Schneider Electric.
269	Output overloaded	The UPS output is overloaded (>105%).	Reduce the load.
305	Battery discharged	The battery voltage is below the configured low battery voltage warning level.	Charge the battery. If the battery does not charge, contact Schneider Electric.
331	Battery not connected	The battery breaker BB is open.	Contact Schneider Electric.
803	SBS inoperable	The communication to the static bypass switch is not working or DC is detected during requested static bypass operation.	Contact Schneider Electric.
807	Bypass out of tolerance	The bypass voltage is outside the configured tolerance, a phase is missing, there is an incorrect phase rotation, or the frequency is outside the configured tolerance.	-
812	Mains out of tolerance	The mains input voltage is outside the configured tolerance, a phase is missing, there is an invalid phase rotation, or the frequency is outside the configured tolerance.	-
814	Overtemperature	The UPS measures a temperature above the threshold level in one of the power modules or in one of the transformers.	Check the air inlet and the air filters.
			Check the ambient temperature.
			Check the output load.
			Contact Schneider Electric.
825	Fan inoperable	One of the transformer fans, static bypass switch fans, or power module fans is inoperable.	Contact Schneider Electric.
830	Rectifier inoperable	The PFC rectifier or the charger is inoperable.	Contact Schneider Electric.
831	Inverter inoperable	The inverter is inoperable.	Contact Schneider Electric.

Input Contacts and Output Relays

The input contacts and output relays are connected on the external connection board 0P2553. The default configuration settings are shown.

Alarm number	Name	Description	Location	Alarm text	Alarm description
15	Option 1 OUT	Output relay: Battery operation	J1608 on 0P2553	Battery operation	The system is in battery operation.
161	Option 2 OUT	Output relay: Static bypass operation	J1609 on 0P2553	SBS ON	The system is in static bypass operation. The bypass supplies the load (temporary or requested static bypass operation).
440	EPO	Input contact: Emergency power off	J1602 on 0P2553	EPO	The digital input "emergency power off (EPO)" is activated (contact open) or the EPO wiring is disconnected.
738	Option 1 IN	Input contact: Block boost/initial charge	J1600 on 0P2553	BlockBst/Init	Block boost and initial charge.
739	Option 2 IN	Input contact: Force to boost charge	J1601 on 0P2553	ForceToBoost	Transfers the UPS into boost charge mode.
800	Common Alarm	Output relay: Common alarm	J1607 on 0P2553	Common Alarm	There is at least one pending alarm in the system.

Schneider Electric
35 rue Joseph Monier
92500 Rueil Malmaison
France

+ 33 (0) 1 41 29 70 00

www.schneider-electric.com

As standards, specifications, and design change from time to time,
please ask for confirmation of the information given in this publication.

© 2016 – 2018 Schneider Electric. All rights reserved.

990-9969B-001